

Review for Midyear Exam

1. An airplane flying at a speed of 150 m/s at a heading of 55° north of west is then acted upon by wind blowing at an incredible speed of 50 m/s west. Using a scale of 1 cm = 25 m/s, draw the vectors and find the resultant speed of the airplane.
2. A golf ball is hit so that its initial speed is 80 m/s at an angle of 20° with the level ground.
 - a. Calculate the horizontal and vertical components of the velocity.
 - b. How long will the ball remain in the air?
 - c. How far away does it land?
 - d. What is the ball's acceleration at its highest point?
 - e. What is the horizontal component of the ball's velocity after 3.2 s?

3. A 30-kg block is pushed with a 100 N force causing it to accelerate at 2 m/s^2 as shown in the diagram at right.
 - a. What is the NET force acting on the block?
 - b. What is the magnitude and direction of the frictional force acting on the block?

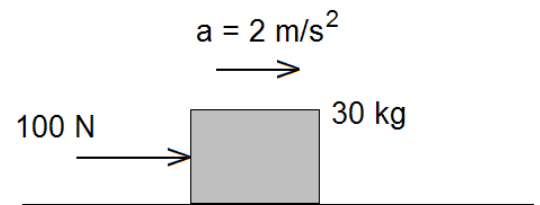

4. A ball is *thrown* down from the top of a building 50 meters high. The velocity of the ball *just before* hitting the ground is 40 m/s. What must the velocity with which the ball was thrown be? (Neglect the effects of air resistance) [25 m/s]

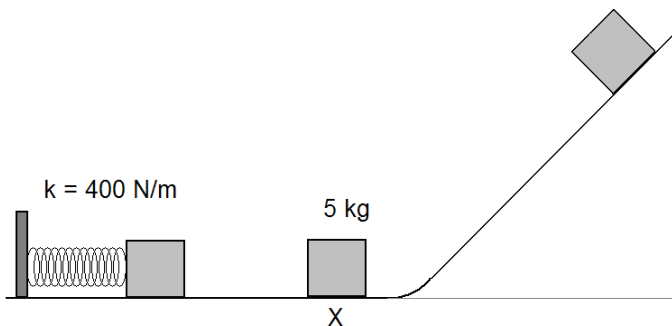

5. A spring (with spring constant of 400 N/m) compressed by 0.5 meters pushes a 5 kg block at rest along a frictionless surface as shown.
 - a. What is the potential energy stored in the spring before the spring is released?
 - b. What will the speed of the 5 kg block be at point X?
 - c. How high up the incline will the block go?

6. A student pulls a 1.6 kg laboratory cart at constant velocity along a flat horizontal table and measures the force required to keep the cart in constant motion. The spring scale reads 5.0 N.
 - a. What must the frictional force acting on the cart be?
 - b. Find the coefficient of kinetic friction between the cart and the table.
 - c. If the force exerted by the spring scale is now increased to 8.0 N, what will the acceleration of the cart become?

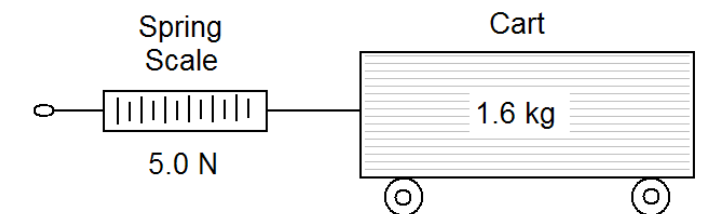

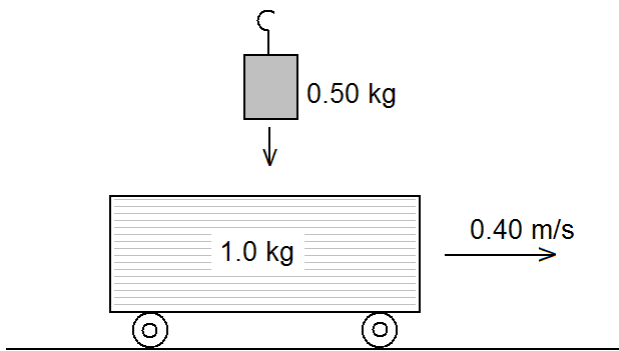



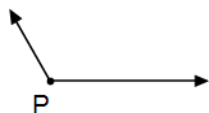

7. In a laboratory experiment, a student gently drops a 0.50 kg mass straight down onto a 1.0 kg laboratory cart traveling on a frictionless surface with a velocity of 0.40 m/s to the right as shown in the diagram below. The mass remains on the cart, and the velocity of the cart with the mass added is measured.
- What is the momentum of the cart before the mass is dropped onto it?
 - Calculate the final velocity of the cart-mass system after the mass is dropped.

- The mass of a physics textbook is closest to
 (A) 10^3 kg (B) 10^1 kg
 (C) 10^0 kg (D) 10^{-2} kg
- A baseball player runs 27.4 meters from the batter's box to first base, overruns first base by 3.0 meters, and then returns to first base. Compared to the total distance traveled by the player, the magnitude of the player's total displacement from the batter's box is
 (A) 3.0 m shorter (B) 3.0 m longer
 (C) 6.0 m shorter (D) 6.0 m longer
- Scalar is to vector as
 (A) speed is to velocity
 (B) displacement is to distance
 (C) displacement is to velocity
 (D) speed is to distance
- The diagram below represents two forces acting concurrently on an object at point P .

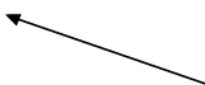

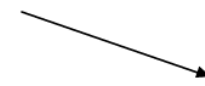
Which diagram best represents the resultant of these two forces?

- (A)  (B) 
- (C)  (D) 

- A 30 N force and a 60 N force act concurrently on an object. Which of the following is *not* a possible value for the equilibrant?
 (A) 30 N (B) 60 N
 (C) 90 N (D) 120 N

- A child pulls a wagon at a constant velocity along a level sidewalk. The child does this by applying a 22-newton force to the wagon handle, which is inclined at 35° to the sidewalk as shown below.

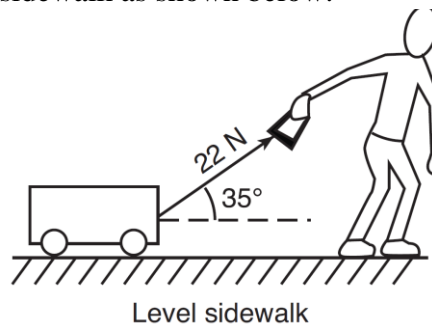

What is the magnitude of the force of friction on the wagon?

- A laboratory cart starting from rest accelerates uniformly at 0.4 m/s^2 as it rolls 20 meters down an incline. How much time is required for the cart to roll the 20 meters?
- A laser pulse is sent from the earth to the moon and is reflected back. The signal takes 2.7 seconds to complete the trip. What is the approximate distance from the earth to the moon?
- If a car accelerates uniformly from rest to 15 m/s over a distance of 100. m, then what is the magnitude of the car's acceleration?
- A ball is thrown straight up with a speed of 12 meters per second near the surface of Earth. What is the maximum height reached by the ball? (Neglect air friction.)

11. Which graph best represents the motion of an object falling from rest near the Earth's surface? [Neglect friction.]

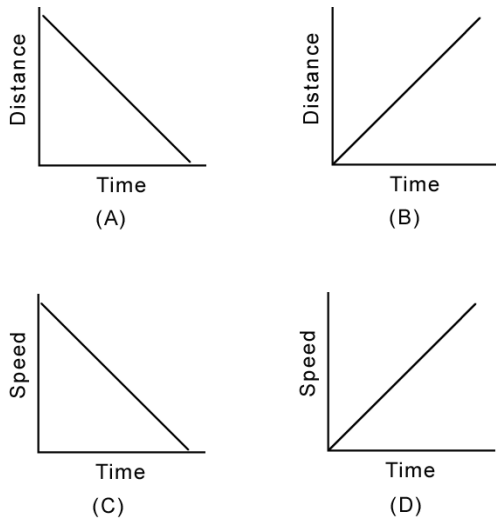

12. A bullet is fired horizontally from the roof of a building 100. meters tall with a speed of 250. meters per second. Neglecting air resistance, how far will the bullet drop in 3.00 seconds?
13. A car traveling on a straight road at 15.0 meters per second accelerates uniformly to a speed of 21.0 meters per second in 12.0 seconds. What is the total distance traveled by the car in this 12.0-second time interval?
14. When an unbalanced force of 10. newtons is applied to an object whose mass is 4.0 kilograms, what will the acceleration of the object be?
15. Compared to 8 kilograms of feathers, 6 kilograms of lead has
- less mass and less inertia
 - less mass and more inertia
 - more mass and less inertia
 - more mass and more inertia
16. A person weighing 600 newtons stands on a spring scale in an elevator. If the scale reads 580 newtons, the elevator must be
- accelerating upward
 - accelerating downward
 - moving upward at constant speed
 - moving downward at constant speed

17. The magnitude of the force that a baseball bat exerts on a ball is 50. newtons. The magnitude of the force that the ball exerts on the bat is
18. What is the weight of a 5.0 kilogram object at the surface of the Earth?
19. What is the net force on the block shown?

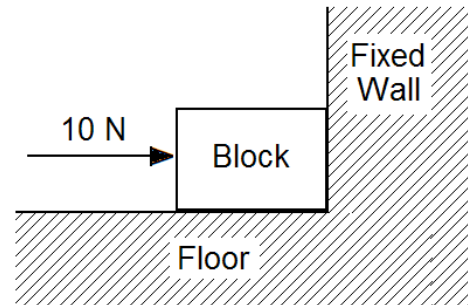

20. Which of the following is the correct unit for the weight of a body?
- $\text{kg}\cdot\text{m}/\text{s}$
 - $\text{kg}\cdot\text{m}/\text{s}^2$
 - $\text{kg}\cdot\text{m}^2/\text{s}^2$
 - $\text{kg}\cdot\text{m}^2/\text{s}^3$
21. An object is brought to rest by a uniform (constant) force. Which factor other than the mass and velocity of the object must be known in order to determine the magnitude of the force required to stop the object?

A 1.00×10^3 kilogram car is driven clockwise around a flat circular track of radius 25.0 meters. The speed of the car is a constant 5.00 meters per second.

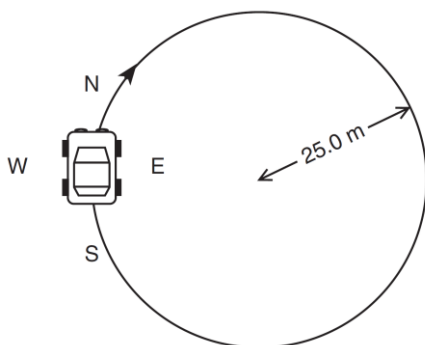

22. What minimum friction force must exist between the tires and the road to prevent the car from skidding as it rounds the curve?
23. If the circular track were to suddenly become frictionless at the instant shown in the diagram, the car's direction of travel would be in what direction?
24. At the instant shown in the diagram, the car's centripetal acceleration is directed towards which direction?
25. Which factor, when doubled, would produce the greatest change in the centripetal force acting on the car?
 (A) mass of the car (B) velocity of car
 (C) radius of the track (D) weight of the car
26. A 20 kg cart traveling east with a speed of 6 meters per second collides with a 30 kg cart traveling west. If both carts come to rest immediately after the collision, what was the speed of the westbound cart before the collision?
27. A 4.0×10^3 watt motor applies a force of 8.0×10^2 newtons to move a boat at constant speed. How far does the boat move in 16 s?

28. Which graph best represents the relationship between the kinetic energy of a moving object and its velocity?

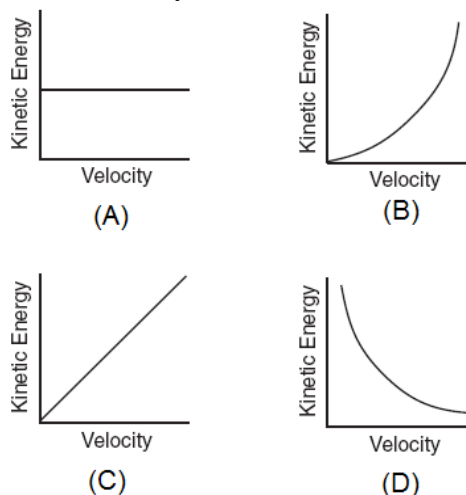

29. Work is measured in the same units as
 (A) force (B) momentum
 (C) mass (D) energy
30. A 20 newton block is at rest at the bottom of an incline as shown in the diagram below.

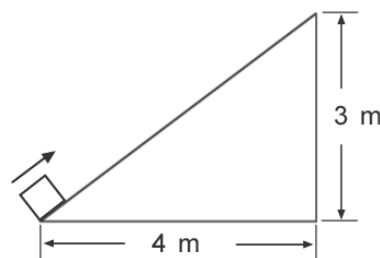

How much work must be done against gravity to move the block to the top of the incline?

31. A 50 kilogram bicyclist starting from rest accelerates along a flat, horizontal road to a speed of 10 meters per second. What is the increase in the bicyclist's potential energy?

The graph below represents the elongation of a spring as a function of the applied force.

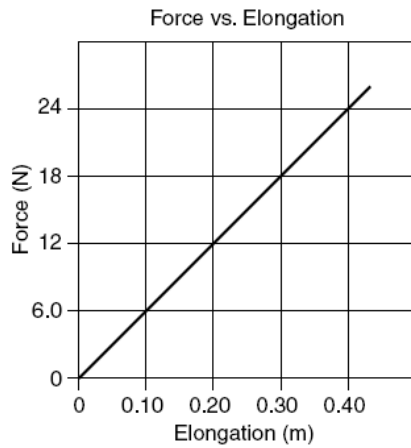

32. How much work must be done to stretch the spring 0.40 meter?
33. What is the spring constant of the spring?
34. The magnitude of the gravitational force between two objects is 20 newtons. If the mass of each object were doubled and the distance between them is also doubled, the magnitude of the gravitational force between the objects would be